

CP2409-RBe

Small-screen auditoriums | Boutique cinema | Screening rooms

Advanced, yet affordable, DCI-compliant cinema projection with laser illumination for screens up to 42' (12.8m)



Key features:

- › **Electronic color convergence (ECC)** – Provides perfect alignment throughout the entire image
- › **Backwards compatibility** – works with existing Christie accessories and lenses
- › **Easy to operate** – adds UX-inspired interface for playback, scheduling and content management
- › **Affordable performance** – eliminate lamp costs and enjoy higher optical efficiency from laser diodes
- › **Ultra-low power standby** – in Hibernate mode the projector will consume less than 3W of power
- › **Long-lasting light source** – delivers stable light output and consistent colors for 50,000 hours



Brilliant electronics that help maintain day-one performance

[LAMPTOLASER.COM](https://lamptolaser.com)

Compare lamp and laser illumination technologies



Specifications

Christie CP2409-RBe

Brightness	nominal	• Up to 9,000 DCI lumens
	lifetime	• >50,000hrs (<25 C ambient) ¹
Contrast ratio		• 2,000:1 full field on/off
Digital micromirror device		• 0.69" S2K 3-chip DMD DLP Cinema® • 2048 x 1080 pixels (2K)
Color gamut		• >DCI-P3
Processing electronics		• Christie CineLife+™ 2K Series (Series-2 IMB compatible) ² • HDMI 2.0 x 2 • 1G Ethernet x1 • Remote UI • Electronic Color Convergence (ECC)
Noise level		• 50 dBA nominal at 25 C ³
Lens mount configuration		• Fully motorized Intelligent Lens System (ILS™)
Lenses		• 1.2 - 1.72 / 1.33 - 2.1 / 1.62 - 2.7 / 2.09 - 3.9 / 0.83 - 1.2 (coming soon)
Input line voltage		• Single phase 200-240V
Hibernate		• <3W
Power consumption		• 1200W max ⁴
Laser class		• Class 1 – Risk Group 3
Automation		• GPIO/Health Connector (RJ-45): x7 opto-isolated GPI (inputs), x3 relay driven GPO (outputs), x1 "Projector Health" status - relay driven output • "Serial-over-Ethernet" based automation
Weight		• As installed: 137lbs (62kg) max
Dimensions (w/o lens)	size (LxWxH)	• 27.4 x 27.1 x 15.6" (696 x 688 x 395mm)
Accessories		• Rack mount stand • Touch panel controller (optional)

¹ Subject to variables specific to each installation. Please see Christie's laser best practices guide for more information.

² Supports Christie IMB-S4 and legacy Series 2 IMBs. A list of supported versions is available upon request.

³ Specific operating conditions may apply.

⁴ Typical power consumption. May be impacted by environmental conditions. Subject to change.

Front view

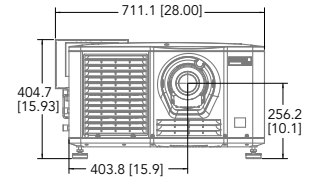

Side view

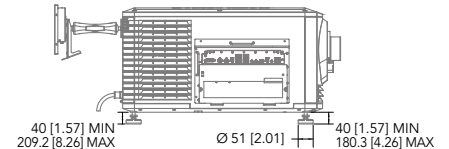

Top view

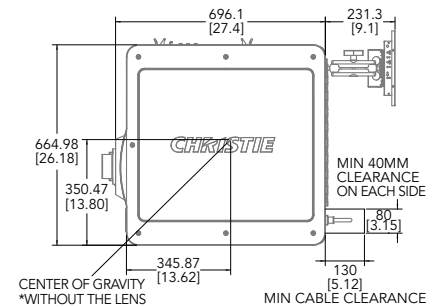

Side view

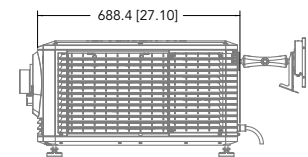

Corporate offices

Worldwide offices

Christie Digital Systems USA, Inc. Cypress PH: +1 714-236-8610	Australia PH: +61 (0) 7 3624 4888	China (Shenzhen) PH: + 86 755 3680 7000	Mexico PH: +52 (55) 4744-1791	United Arab Emirates PH: +971 (0) 4 503 6800
Christie Digital Systems Canada Inc. Kitchener PH: +1 519-744-8005	Brazil PH: +55 11 3181-2952	Colombia PH: +57 (315) 652-9620	Singapore PH: +65 6877 8737	United Kingdom PH: +44 (0) 118 977 8000
	China (Beijing) PH: +86 10 6561 0240	Germany PH: +49 221 99 512-0	South Korea PH: +82 2 702 1601	United States (Arizona) PH: +1 602-943-5700
	China (Shanghai) PH: +86 21 6030 0500	India PH: +91 (080) 6708 9999	Spain PH: +34 (0) 91 633 99 90	United States (Texas) PH: +1 469-757-4420

For the most current specification information, please visit christiedigital.com

Copyright 2024 Christie Digital Systems USA, Inc. All rights reserved. Our centers of excellence for manufacturing in Kitchener, Ontario, Canada and in Shenzhen, China are ISO 9001:2015 Quality Management System-certified. All brand names and product names are trademarks, registered trademarks or tradenames of their respective holders. "Christie" is a trademark of Christie Digital Systems USA, Inc., registered in the United States of America and certain other countries. DLP® and the DLP logo are registered trademarks of Texas Instruments. Performance specifications are typical. Due to constant research, specifications are subject to change without notice.
CD4311-CP2409-RBe-Datasheet-Feb-24-EN

